

# Dimensions and Shipping Weights

Class 500, 600



www.SquareD.com

For the most up-to-date information

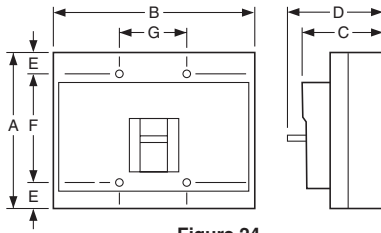

Figure 24

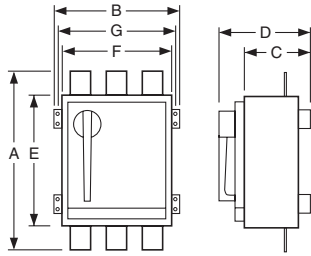

Figure 25

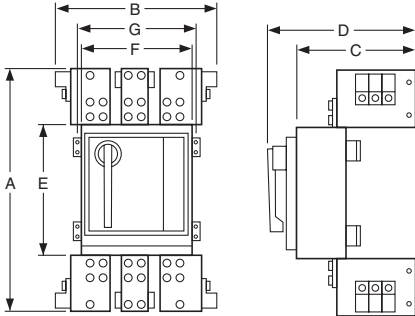

Figure 26

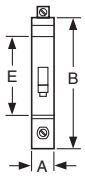

Figure 27

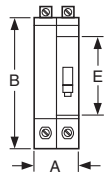

Figure 28

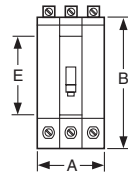

Figure 29

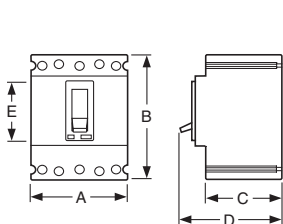
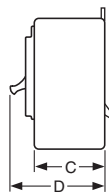

Figure 30

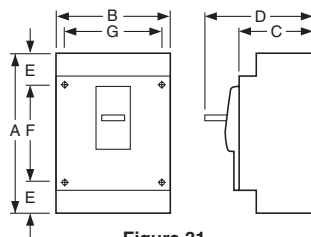

Figure 31

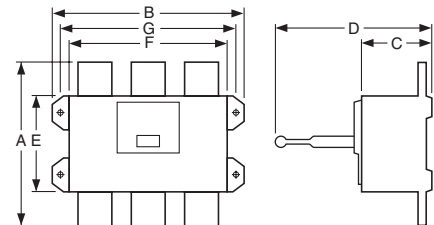

Figure 32

## LC, LI, LE, LX, LXI, NA, NE, NX, PA, PC, PE and PX Circuit Breakers

Circuit Breaker Catalog No. Prefix	No. Poles	Fig. No.	Dimensions—Inches						
			A	B	C	D	E	F	G
LC, LI, LE, LX, LXI	2 & 3	24	11.86	7.50	5.48	6.74	0.55	10.75	2.50
PA, PH, PX, PE	2 & 3	25	20.06	13.70	7.25	10.47	14.00	12.00	12.75
PC, PX-25, PE-20-25	2 & 3	26	26.10	23.30	13.33	16.55	14.10	12.00	...

## ED, EG and EJ Circuit Breakers

Circuit Breaker Catalog No. Prefix	No. of Poles	Fig. No.	Dimensions — Inches				
			A	B	C	D	E
ED, EG, EJ	1	27	0.98	5.66	3.09	4.05	3.32
	2	28	1.96	5.66	3.09	4.05	3.32
	3	29	2.94	5.66	3.09	4.05	3.32
GJ	3	30	3.54	4.72	2.76	3.94	2.20

## PG, PJ, PL, RG, RJ and RL Circuit Breakers

Circuit Breaker Catalog No. Prefix	No. of Poles	Fig. No.	Dimensions — Inches						
			A	B	C	D	E	F	G
MG, MJ	2, 3	31	12.80	8.27	5.53	8.05	4.19	7.87	7.87
PG, PJ, PL	2, 3	31	16.29	8.27	5.53	8.05	4.19	7.87	7.87
RG, RJ, RL	2, 3	32	15.00	16.54	6.30	14.38	8.73	14.25	15.35

Frame Size	Approx. Shipping Weight (Lbs.)
ED, EG, EJ 1-pole	2
ED, EG, EJ 2-pole	3
ED, EG, EJ 3-pole	4
FAL	2
FHL 1-pole	
FAL	
FAL	3
FHL 2-pole	
FCL	
FAL	5
FHL 3-pole	
FCL	
FIL	8
GJ	3
KAL	7
KHL	
KCL	
KIL	9
LAL	15
LHL	

Frame Size	Approx. Shipping Weight (Lbs.)
LEL	25
LCL	
LIL	
LXL	
MAL	34
MHL	
PAF	69
PHF	
PG	32
PJ	
PL	
PXF	80
PEF	
RG	52
RJ	
RL	
QB, QD, QG, QJ	4
Q4L	15

All weights are for 3-pole circuit breakers unless otherwise noted.